

# edesa

DECORATIVE CHIMNEY-STYLE



## ECP-6611 BK

Cod. 932271956

EAN 8422248358736

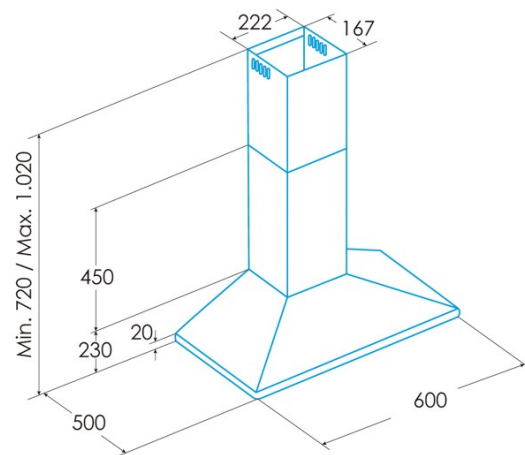

### GENERAL INFORMATION

|           |               |
|-----------|---------------|
| EAN/UPC   | 8422248358736 |
| Subfamily | Chimney       |

### Product sheet according to directives EU65/2014 - EN61591, EN60704-2-13, EN50564

|   |      |
|---|------|
| AEC (Annual energy consumption) (kWh/year)    | 95,7 |
| EEL class (energy efficiency class)           | C    |
| FDE (fluid dynamic efficiency)                | 17,8 |
| FDE class (fluid dynamic efficiency class)    | D    |
| LE (light efficiency) (lux/W)                 | 38,4 |
| LE class (light efficiency class)             | A    |
| GFE (grease filtering efficiency)             | 90,3 |
| GFE class (grease filtering efficiency class) | B    |
| Airflow in normal mode MIN (m3/h)             | 385  |
| Airflow in normal mode MAX (m3/h)             | 645  |
| Acoustic power in normal mode MIN (dB)        | 57,8 |
| Acoustic power in normal mode MAX (dB)        | 71,8 |
| Po (energy consumption in off mode) (W)       | 0    |
| Ps (energy consumption in standby mode) (W)   | 0    |

### Integration directive EU 66/2014

|  |       |
|--|-------|
| f (time increase factor)                                   | 1,4   |
| EEL (Energy Efficiency Index)                              | 80,1  |
| QBEP (maximum efficiency at air flow point) (m3/h)         | 371,8 |
| PBEP (maximum efficiency at pressure point) (Pa)           | 314   |
| WBEP (power consumption at maximum efficiency) (W)         | 182,5 |
| WL (nominal power lighting system) (W)                     | 7     |
| EMIDDLE (Average illuminance on the cooking surface) (lux) | 269   |

### External Dimensions

|                           |          |
|---------------------------|----------|
| Width (mm)                | 600      |
| Depth (mm)                | 500      |
| Maximum total height (mm) | 1,02     |
| Minimum total height (mm) | 720      |
| Diamètre de sortie (mm)   | 150, 125 |

### Characteristics

|                                       |                        |
|---------------------------------------|------------------------|
| Motor quantity                        | 1                      |
| Motor model                           | TA                     |
| Maximum pressure (Pa)                 | 430                    |
| Filter technology                     | Aluminium mesh         |
| Control technology                    | Mechanical push button |
| Booster                               | -                      |
| Power levels                          | 3                      |
| Timer                                 | -                      |
| Filter saturation indicator           | -                      |
| Charcoal filter replacement indicator | -                      |
| Dimmer function                       | -                      |
| Connectivity                          | -                      |
| Remote control                        | -                      |
| Display                               | -                      |

### Lighting

|                |        |
|----------------|--------|
| Light model    | ECOLED |
| Ray technology | LED    |

### Installation

|   |          |
|---|----------|
| Minimum distance to electric plate (mm) | 650      |
| Minimum distance to gas plate (mm)      | 650      |
| Recirculation option                    | √        |
| Charcoal filter                         | -        |
| Back draught shutter                    | Included |
| Inner shield                            | -        |

### Electric connection

|                        |         |
|------------------------|---------|
| Nominal voltage (V)    | 220-240 |
| Nominal frequency (Hz) | 50/60   |

|                           |          |
|---------------------------|----------|
| Nominal input power (W)   | 277      |
| Electric shock protection | Class II |
| Power cord length (m)     | 1,5      |

---

**Accessories**

|                                 |           |
|---------------------------------|-----------|
| Upper decorative duct extension | '02862301 |
| White decorative duct           | No        |
| Black decorative duct           | No        |
| Island tube booster             | No        |
| Back draught shutter            | Included  |
| MAX PRO Metal filter            | '02800917 |
| Activated charcoal filter       | '02859391 |
| Noiseless flexible duct         | '02893002 |
| Recirculation kit               | '02894000 |

---