

# edesa

MULTI-FUNCTION OVENS



## EOE-8411 P X

Cod. 921270253

EAN 8422248100304

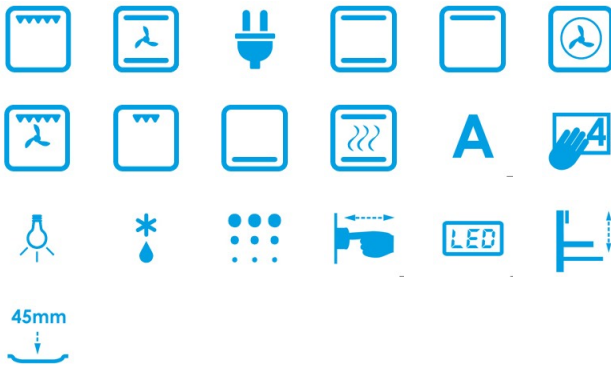

45mm

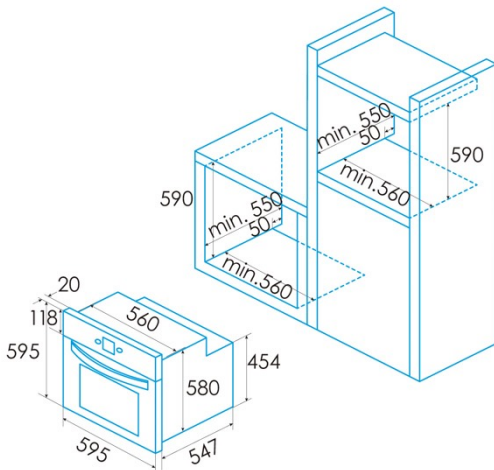

### GENERAL INFORMATION

EAN/UPC	8422248100304
Subfamily	Multifunction

### Product sheet

Energy Efficiency Index (EEI)	94
Energy efficiency class	A
Energy consumption in conventional mode (kWh/cycle)	0,99
Energy consumption in fan mode (kWh/cycle)	0,79
Heat source	Electricity
Appliance mass [Kg]	33,5
Number of cavities	1
Cavity volume (L)	70

### Dimensions

Width (mm)	595
Height (mm)	595
Depth (mm)	575
Built-in width (mm)	560
Built-in height (mm)	590
Built-in depth (mm)	560

### Controls

Control type	Electronic
Display	LCD
Number of functions	12
Functions	Double_Grill;Double grill with fan;Turbo heating;Eco;Pyro;Defrosting;Bottom heating;Top and bottom heating;Top and bottom heating with fan;Grill
Timer	Electronic
On/off indicator	√
Thermostat indicator	√
Minimum temperature [°C]	50
Maximum temperature [°C]	250
Thermal probe	-

### Characteristics

Enamel	Pyrolitic
Drop down grill	-
Removable inner glass	√
Number of light bulbs	25
Bulb power [W]	1
Number of door glasses	4
Manual door lock	√
Soft close	-
Cavity type	Flat
Side racks	√
Levels	5
Telescopic guides	0,5
Convection fan	√

### Safety

Cooling fan	√
Overheating protection	√
Automatic safety shutdown	√
Pyrolysis door lock	√
Pyrolysis lock indicator	√

### Electrical connection

Power of the upper heating element [W]	650
Lower power of the heating element [W]	1100
Turbocharger power [W]	2000
Nominal voltage (V)	220-240
Nominal frequency (Hz)	50/60
Nominal input power (W)	3200
Electric shock protection	Class I
Power cord length (m)	1
Plug type	Type F

---

**Accessories**

Flat tray	-
Deep tray	√
Steam tray	-
Grill	√
Inner grill	-
Telescopic guides	√
Tray handle	-
Removable tank	-
Pizza stone	-
Roast kit	-

---